



MOROOKA

MST110F

Forwarder <F Series>

11,000kg
Payload



- Max. payload 11,000kg
- Electric Control Joystick
- Auto Deceleration
- Hardox in My body certified dump bed

**Cummins QSB6.7 Engine
Tier 4 Final / EU Stage V**

Greatly reduces emissions of PM (particulate matter) and NOx (nitrogen oxides), contributes to environmental protection.

MST 110 F

Consideration for the Environment

Conforming to Tier 4 Final / EU Stage V

It is equipped with the environmentally friendly EU Stage V compatible engine

Auto Deceleration

When idling continues for certain period of time, engine speed automatically lowers to improve fuel efficiency, noise and CO2 emission are also reduced.

Contributing to Productivity Improvement

Improvement of Driver-ability and Operability

5% faster running speed than conventional model
Newly adapted joystick reduces operator fatigue and provides intuitive operation feeling

Improvement of durability in dump bed

Introduction of wear-resistant steel Hardox® greatly improves durability of dump bed and contributes reduction of running cost

Specifications

MODEL	MST110F
	Metric
Performance	
Maximum Payload	11,000 kg
Travel Speed (High / Low)	10.5 / 7.5 km/h
Ground Pressure (Empty / Loaded)	33.5 / 59.5 kPa
Machine Dimension and Weight	
Operating Weight	14,200 kg
Overall Length	6,790 mm
Overall Width (Transport)	2,850 mm
Overall Height	3,160 mm
Min. Ground Clearance	480 mm
Crawler Width	750 mm
Dump Body	
Dump Shape	Flat Bed
Length x Width	4020 x 2500 mm
Engine	
Name	Cummins B6.7
Nominal Output	186 kw (252.9CH)/2,000 rpm
Tank Capacity	
Fuel Tank Capacity	266 L
Hydraulic Oil Tank Capacity	125 L
DEF Tank Capacity	33.54 L
Emission Standard	Tier4 Final / EU Stage V

Pursuing Safety and Comfort

ROPS/FOPS Cabin

The cabin complies with ROPS and FOPS standards and includes air conditioning as a standard feature.

Cabin Guard

The cabin guard is installed on the sides and front of the cabin as standard, enhancing safety

Improvement in maintainability

Easing regular maintenance

Filters, DEF tank and air cleaner are centrally arranged for easy maintenance.



Cabin Guard



Filters



Operator seat



Centralized auxiliary equipment

Dimensions

Unit : mm

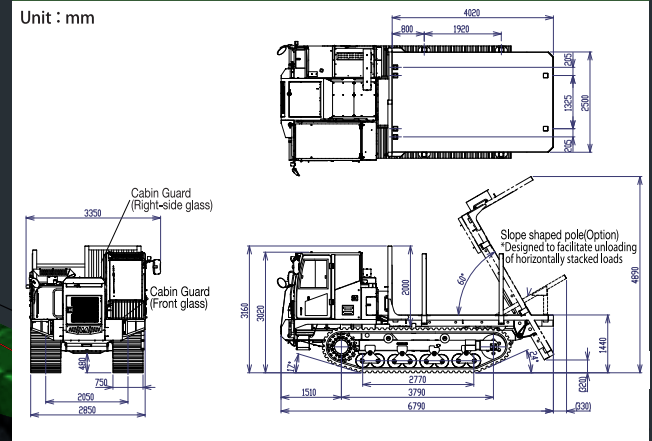

● Specifications are subject to change without notice.

MOROOKA EUROPE

Im Neugrund 14
64521 Gross-Gerau, Germany
Tel: +49 (0)61529778-0
Fax: +49 (0)61529778-15
Web: www.morookaeurope.com

CONTACT